

PLAN VIEW  
1:250

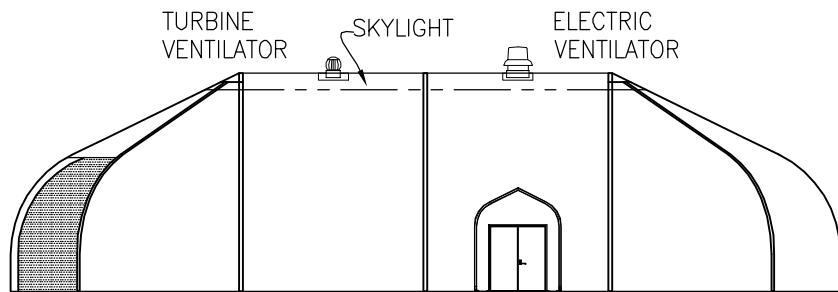

ELEVATION  
1:250

- THE FOLLOWING DOORS ARE AVAILABLE AT EXTRA CHARGE:
- SINGLE PERSONNEL DOOR 914w x 2134h (C/W 2870w HOOD)
  - DOUBLE PERSONNEL DOOR 1829w x 2134h (C/W 2870w HOOD)
  - SIDE SLIDING CARGO DOOR 5969w x 4419h
  - END SLIDING CARGO DOOR TOP 4089w, BASE 5510w x 4419h
  - DOUBLE PANEL ROLLING DOOR TOP 1610w, BASE 7250w x 6477h (SEE DPRD-50)
  - TRIPLE PANEL ROLLING DOOR TOP 2350w, BASE 10325w x 6477h (SEE TPRD-50)

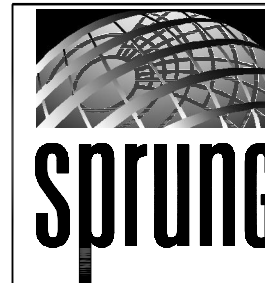
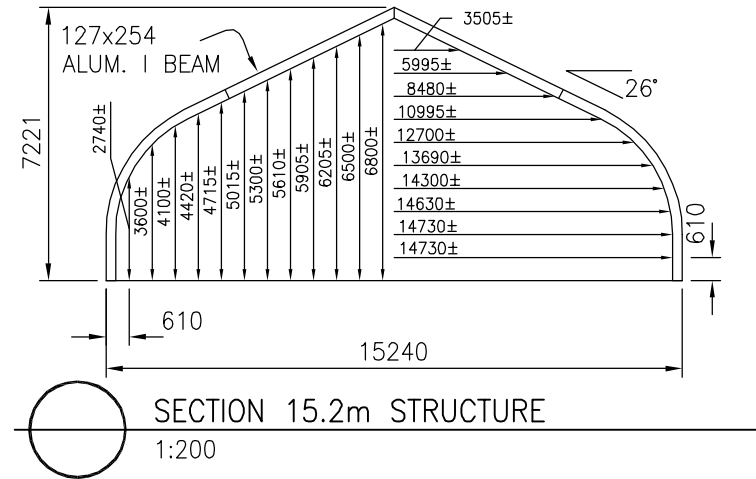

SIGNATURE SERIES

SIGNATURE SERIES  
15.2m WIDE  
STRUCTURE

DATE  
11/16/2005

SCALE  
AS NOTED

DRAWING #  
S-50 (6.1m OC) METRIC